

Grinding AUTO REST® | GR-6000-000

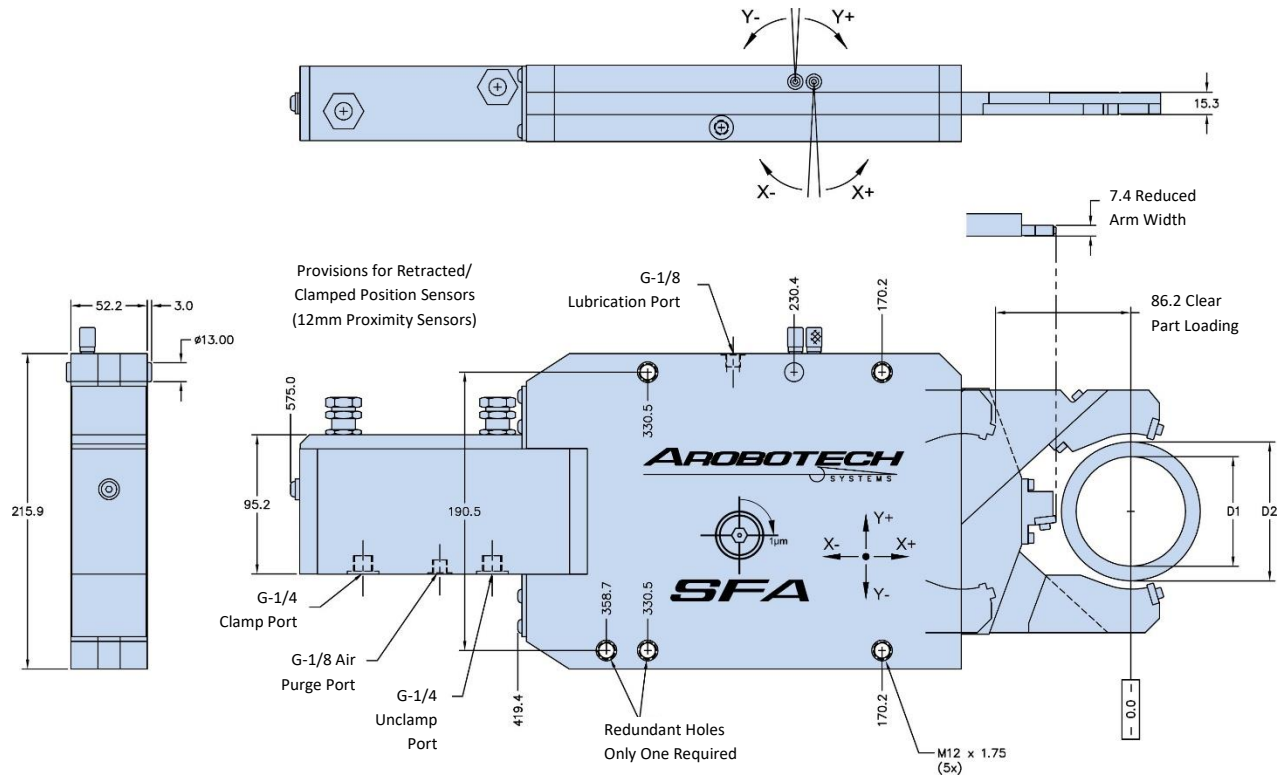

Nest Set			1	2	3	4	5	6	7
Minimum Clamp Diameter	D1	mm	15	25	35	45	55	65	75
Maximum Clamp Diameter	D2	mm	35	45	55	65	75	85	95

X-Axis Adjustment per Screw Rotation	mm	0.004
X-Axis Adjustment Total	mm	±0.20
Y-Axis Adjustment per Screw Rotation	mm	0.004
Y-Axis Adjustment Total	mm	±0.20
Piston Area	cm ²	11.4
Cylinder Stroke	mm	125.2
Operating Pressure	bar	10 – 27
Maximum Pressure	bar	32
Air Purge Pressure	bar	0.3 – 0.5
Lubrication Volume	cm ³	0.10 – 0.15
Lubrication Frequency		Working Cycle (or every 6 minutes)
Repeatability	mm	±0.001
Mass	kg	27
Max Lifting Capacity	Kg	83



Included Features

- * Arm Retraction for Part Loading
- * Extended Reach for Clearance
- * Fixed or Follow Down Operation
- * Upper Arm Gage Clearance
- * 2-Axis Centerline Adjustment
- * 90° = 0.001mm Adjustment
- * Position Feedback Sensor
- * Visible Zero Adjustment Screw

Items Required to Use This Product:

- * Set of Nests
- * Set of Wear Pads
- * Mounting Base

Contact Us For Full Technical Details And Customer Service

sales@arobotech.com

www.arobotech.com