

Nest Set			1	2	3	4	5
Minimum Clamp Diameter	D1	mm	30	52	74	96	118
Maximum Clamp Diameter	D2	mm	52	74	96	118	140

X-Axis Adjustment per Screw Rotation	mm	0.004
X-Axis Adjustment Total	mm	±0.20
Y-Axis Adjustment per Screw Rotation	mm	0.004
Y-Axis Adjustment Total	mm	±0.20
Piston Area	cm ²	20.3
Cylinder Stroke	mm	178
Operating Pressure	bar	10 – 27
Maximum Pressure	bar	32
Air Purge Pressure	bar	0.3 – 0.5
Lubrication Volume	cm ³	0.25 – 0.35
Lubrication Frequency		Working Cycle (or every 6 minutes)
Repeatability	mm	±0.001
Mass	kg	64
Max Lifting Capacity	Kg	127

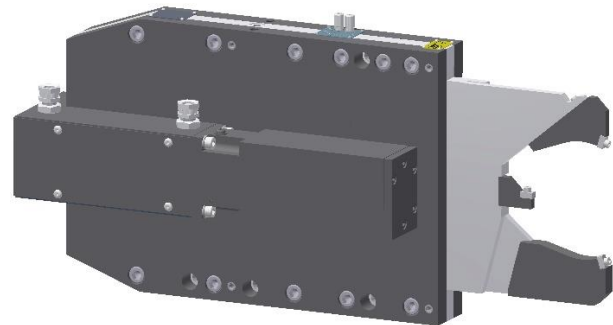

Included Features

- * Arm Retraction for Part Loading
- * Extended Reach for Clearance
- * Fixed or Follow Down Operation
- * Upper Arm Gage Clearance
- * 2-Axis Centerline Adjustment
- * 90° = 0.001mm Adjustment
- * Position Feedback Sensor
- * Visible Zero Adjustment Screw

Items Required To Use This Product:

- * Set of Nests
- * Set of Wear Pads
- * Mounting Base