

# SFA Models

(Superior Fine Adjustment)

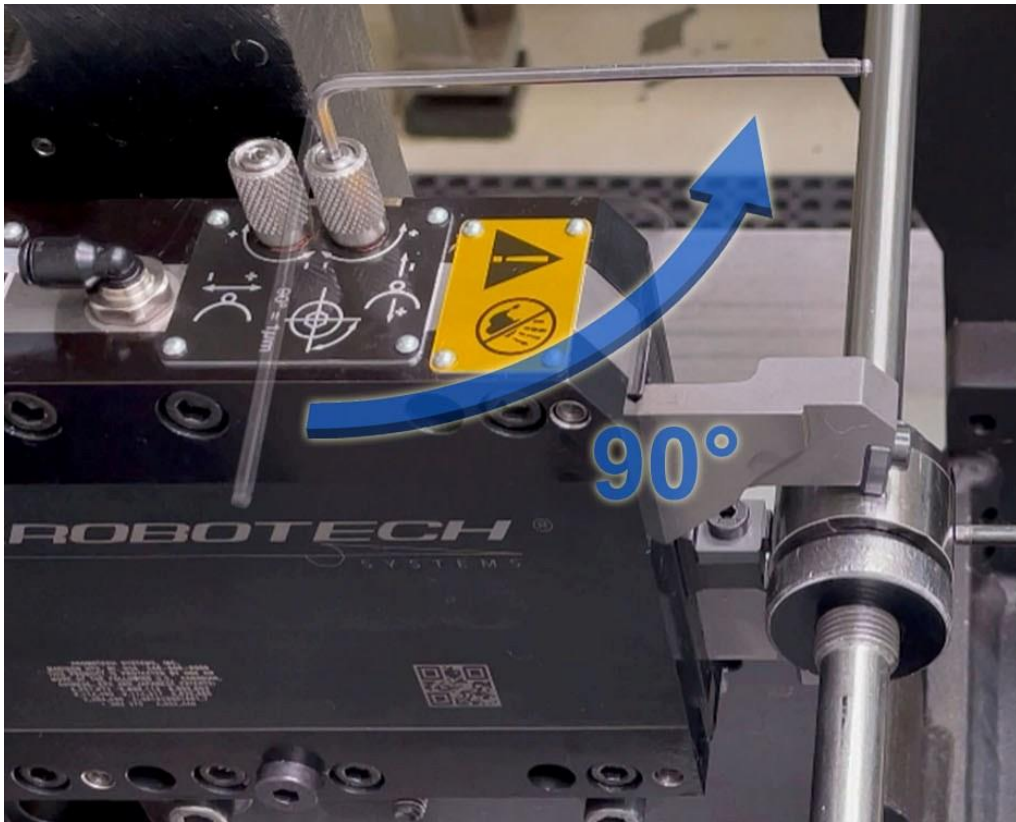

**90° = 0.001mm Adjustment**

**WORLD LEADER IN STEADY REST TECHNOLOGY**

[www.arobotech.com](http://www.arobotech.com)

## About us

Arobotech Systems is the world leader in providing steady rests for use on grinding machines. Grinding AUTO REST<sup>®</sup> is recognized as the industry standard.

Sales and service are provided from our World Headquarters in Madison Heights, Michigan with additional sales and/or service locations in Germany, Japan, China, India, and Korea.



## How it works

### Accuracy

Arobotech Systems offers the original sliding wedge design with unsurpassed clamping accuracy. Each Grinding AUTO REST<sup>®</sup> must repeat within .001mm during testing to pass our rigorous certification criteria.

### Self-Centering

The straight-line motion produced by the sliding wedge design gives Grinding AUTO REST<sup>®</sup> its unique self-centering capability. This feature automatically centers any size within each model's clamping range.

### Follow Down Operation

This feature allows the Grinding AUTO REST<sup>®</sup> to support the part at the point of grind. The dynamic self-centering ability compensates for the changing part size to keep the workpiece on center throughout the grind cycle.

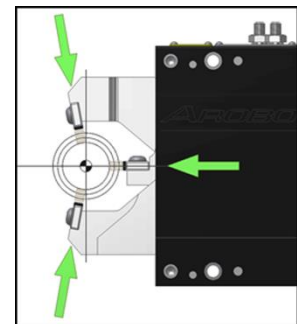

## Benefits of use

### Quality improvements

- Improve roundness – Our Follow Down feature supports the diameter being ground
- Better size control by keeping the workpiece stable throughout the grind cycle
- Improve concentricity – Our Self-Centering feature automatically compensates for under- and over-sized parts

### Other benefits

- Reduce scrap by reliably holding the workpiece accurately in place every time
- Improve cycle time with more aggressive grinding
- Accurately support workpiece without using a tailstock
- Models available from 1 to 250mm diameters
- Quick change-over

**Content**

O.D. Grinding ..... Page 3 - 8  
 Crankshaft Grinding ..... Page 9 – 13  
 Machine Prep ..... Page 14  
 Mounting ..... Page 15  
 Accessories ..... Page 16  
 Service ..... Page 17  
 Repair ..... Page 18

**Tooling Configurations**

Grinding AUTO REST<sup>®</sup> model and configuration is chosen based on workpiece size and grinding technical requirement. Models that feature wear pads mounted directly to the arms often represent the best value. Nest design is required for larger sizes and special features (offset, extended, etc.)

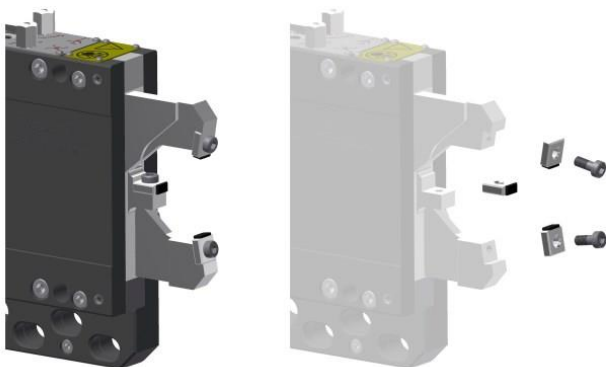

**Direct Mounted Wear Pads**

- Wear Pads ordered by set (3 per set)
- Set number specifies clamping range
- Offset and special pads available - contact sales@arobotech.com

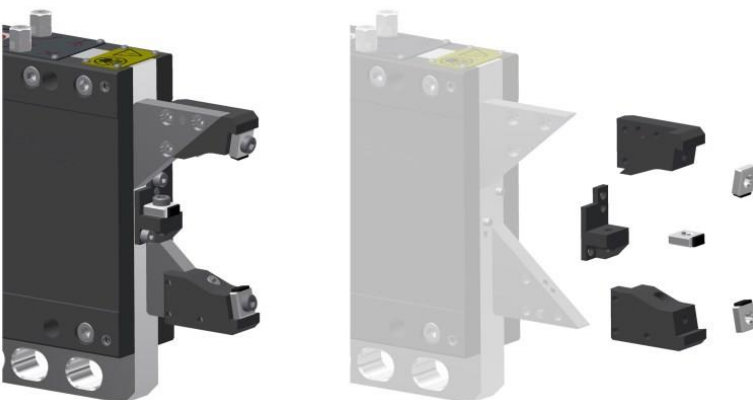

**Nest Mounted Wear Pads**

- Nests ordered by set (3 per set)
- Set number specifies clamping range
- Alternate angle center nests available in the event of quality issues
- Offset and special nests available - contact sales@arobotech.com
- Offset and special pads available - contact sales@arobotech.com

**Product Overview - O.D. Models**

Available features:

- Arm Retraction for Part Loading
- Fixed or Follow Down Operation
- 2-Axis SFA 0.001mm / 90° Centerline Adjustment
- Visible Zero Adjustment Screws
- Upper Arm Gage Clearance
- Position Feedback Sensors
- Lower Mounting Rail
- Side Mount Cylinder

\*\*\* See Data Sheet for Specific Features of Each Model \*\*\*

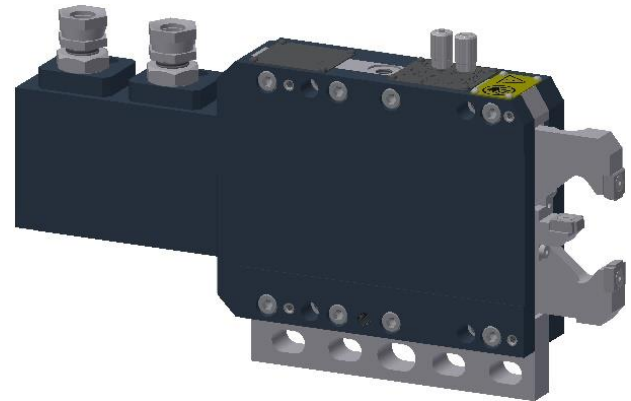

**OD Grinding Models – Direct Mounted Wear Pads**

Model		GR-4000		GR-4020		GR-4100	
Replaces		GC29222Y		GR-3520V		GR-6030V	
Clamp Range	mm	2 – 30		15 – 40		15 – 60	
<b>Pad Set 1</b>		2 – 4		15 – 35		15 – 50	
<b>Pad Set 2</b>			4 – 12		20 – 40		25 - 60
<b>Pad Set 3</b>				12 - 30			

**OD Grinding Models – Nest Mounted Wear Pads**

Model		GR-4300			GR-4400		
Replaces		GR-115V			GR-320V		
Maximum Size	mm	60			90		
<b>Nest Set 1</b>		15 – 30			10 – 30		
<b>Nest Set 2</b>			30 – 45			30 – 50	
<b>Nest Set 3</b>				45 - 60			50 – 70
<b>Nest Set 4</b>					n/a		70 - 90

Contact sales@arobotech.com for free assistance

- \* Model Selection
- \* Process Review
- \* Special Models
- \* 3D Models
- \* Accessories
- \* Machine Integration
- \* Modifications
- \* Special Features
- \* Mounting Bases
- \* Spare Parts

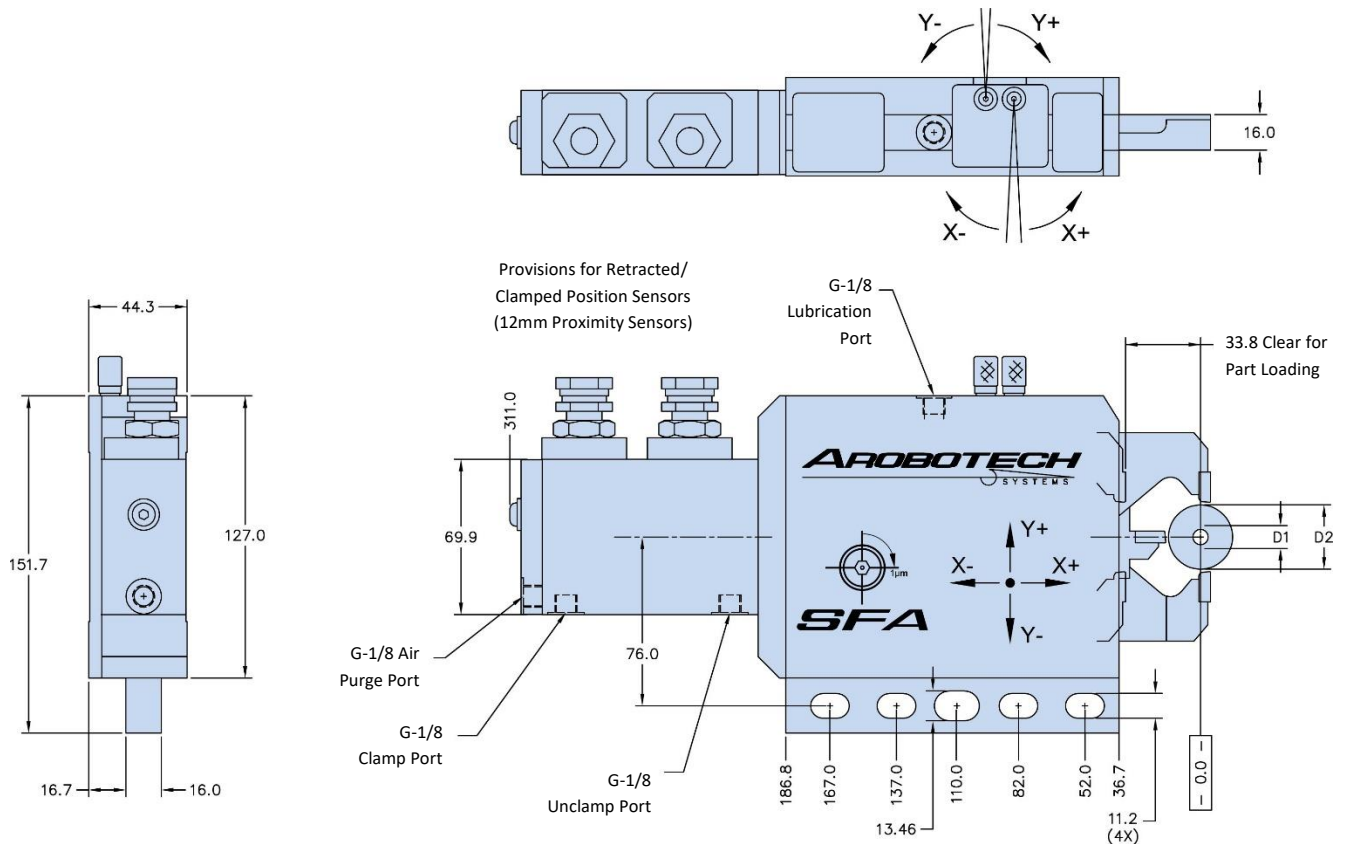

Wear Pad Set			1A	2A	3A
Minimum Clamp Diameter	D1	mm	2	4	12
Maximum Clamp Diameter	D2	mm	4	12	30

X-Axis Adjustment per Screw Rotation	mm	0.004
X-Axis Adjustment Total	mm	±0.20
Y-Axis Adjustment per Screw Rotation	mm	0.004
Y-Axis Adjustment Total	mm	±0.20
Piston Area	cm <sup>2</sup>	6.4
Cylinder Stroke	mm	51
Operating Pressure	bar	15 – 30
Maximum Pressure	bar	45
Air Purge Pressure	bar	0.3 – 0.5
Lubrication Volume	cm <sup>3</sup>	0.03 – 0.04
Lubrication Frequency		Working Cycle (or every 6 minutes)
Repeatability	mm	±0.001
Mass	kg	8.3
Max Lifting Capacity	kg	43

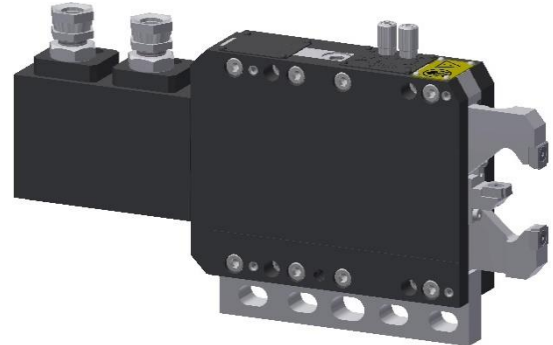

#### Included Features

- \* Arm Retraction for Part Loading
- \* Fixed or Follow Down Operation
- \* 2-Axis Centerline Adjustment
- \* 90° = 0.001mm Adjustment
- \* Visible Zero Adjustment Screws
- \* Position Feedback Sensors

#### Items Required to Use This Product:

- \* Set of Wear Pads
- \* Mounting Base

# Grinding AUTO REST® | GR-4020-000

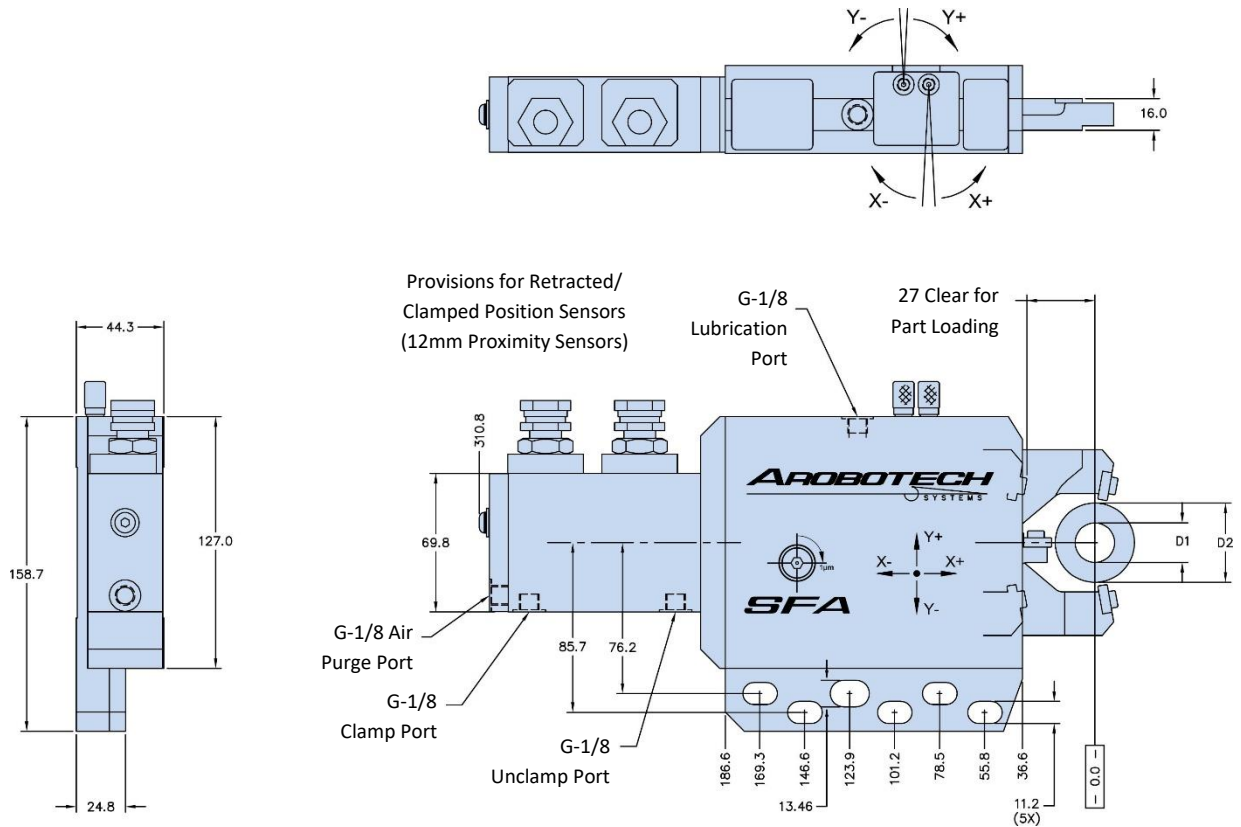

Wear Pad Set			1	2
Minimum Clamp Diameter	D1	mm	15	20
Maximum Clamp Diameter	D2	mm	35	40

X-Axis Adjustment per Screw Rotation	mm	0.004
X-Axis Adjustment Total	mm	±0.20
Y-Axis Adjustment per Screw Rotation	mm	0.004
Y-Axis Adjustment Total	mm	±0.20
Piston Area	cm <sup>2</sup>	6.4
Cylinder Stroke	mm	51
Operating Pressure	bar	15 – 30
Maximum Pressure	bar	45
Air Purge Pressure	bar	0.3 – 0.5
Lubrication Volume	cm <sup>3</sup>	0.03 – 0.04
Lubrication Frequency		Working Cycle (or every 6 minutes)
Repeatability	mm	±0.001
Mass	kg	8.5
Maximum Lifting Capacity	Kg	43

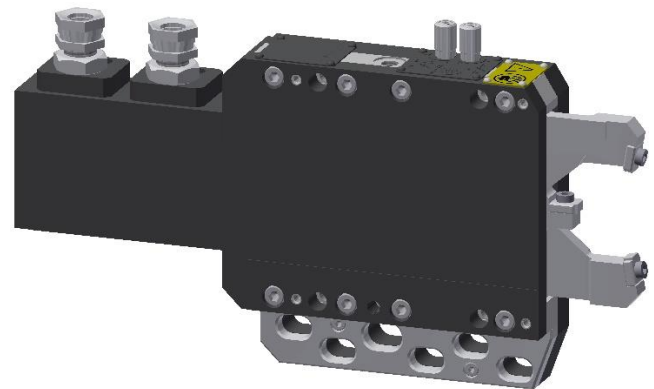

#### Included Features

- \* Arm Retraction For Part Loading
- \* Fixed or Follow Down Operation
- \* 2-Axis Centerline Adjustment
- \* 90° = 0.001mm Adjustment
- \* Visible Zero Adjustment Screws
- \* Position Feedback Sensors

#### Items Required To Use This Product:

- \* Set of Wear Pads
- \* Mounting Base

Contact Us For Full Technical Details And Customer Service

sales@arobotech.com

www.arobotech.com

# Grinding AUTO REST® | GR-4100-000

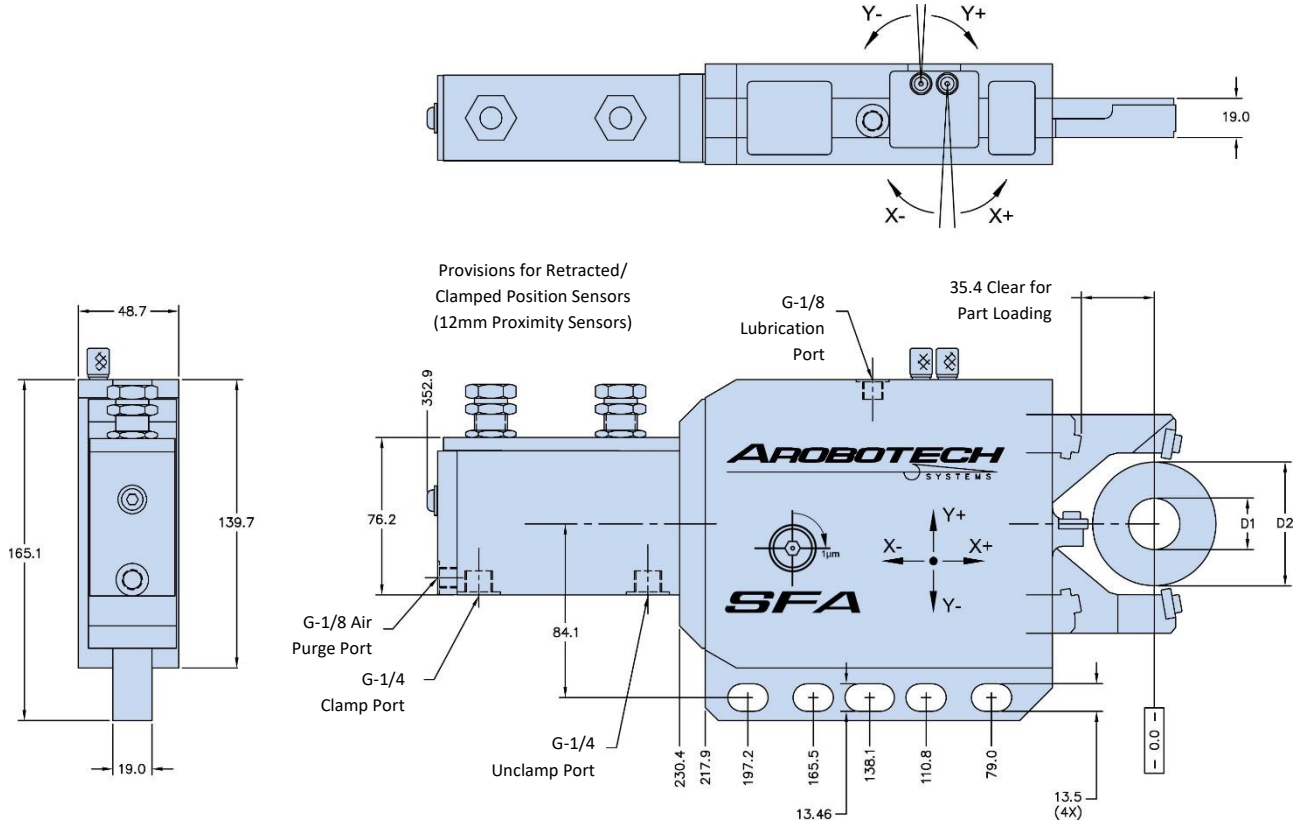

Wear Pad Set			1	2
Minimum Clamp Diameter	D1	mm	15	25
Maximum Clamp Diameter	D2	mm	50	60

X-Axis Adjustment per Screw Rotation	mm	0.004
X-Axis Adjustment Total	mm	±0.20
Y-Axis Adjustment per Screw Rotation	mm	0.004
Y-Axis Adjustment Total	mm	±0.20
Piston Area	cm <sup>2</sup>	6.4
Cylinder Stroke	mm	69.5
Operating Pressure	bar	15 – 30
Maximum Pressure	bar	45
Air Purge Pressure	bar	0.3 – 0.5
Lubrication Volume	cm <sup>3</sup>	0.04 – 0.06
Lubrication Frequency		Working Cycle (or every 6 minutes)
Repeatability	mm	±0.001
Mass	kg	11
Max Lifting Capacity	Kg	43

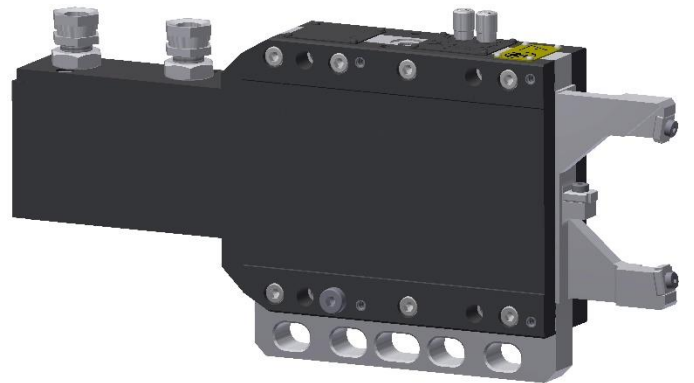

#### Included Features

- \* Arm Retraction for Part Loading
- \* Fixed or Follow Down Operation
- \* 2-Axis Centerline Adjustment
- \* 90° = 0.001mm Adjustment
- \* Visible Zero Adjustment Screws
- \* Position Feedback Sensors

#### Items Required To Use This Product:

- \* Set of Wear Pads
- \* Mounting Base

Contact Us For Full Technical Details And Customer Service

sales@arobotech.com

www.arobotech.com

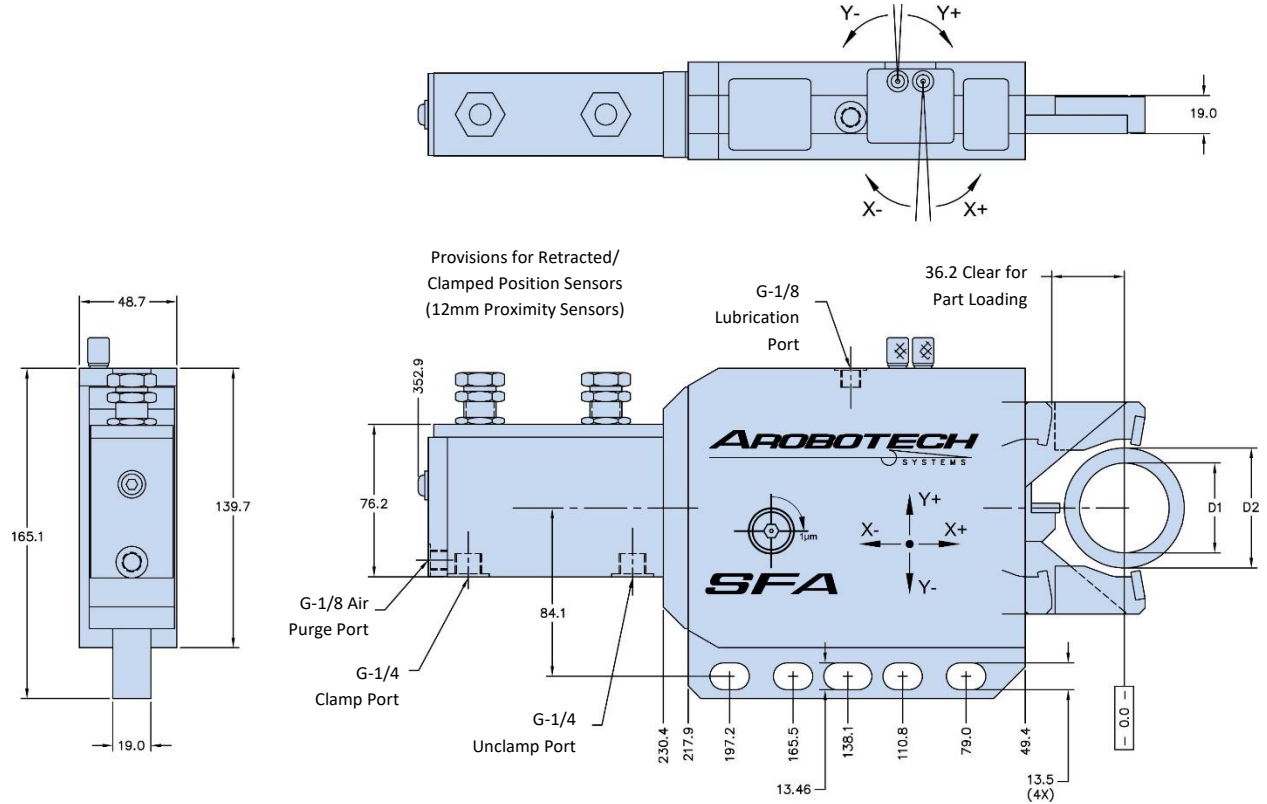

Nest Set			1	2	3
Minimum Clamp Diameter	D1	mm	15	30	45
Maximum Clamp Diameter	D2	mm	30	45	60

X-Axis Adjustment per Screw Rotation	mm	0.004
X-Axis Adjustment Total	mm	±0.20
Y-Axis Adjustment per Screw Rotation	mm	0.004
Y-Axis Adjustment Total	mm	±0.20
Piston Area	cm <sup>2</sup>	6.4
Cylinder Stroke	mm	57.5
Operating Pressure	bar	15 – 30
Maximum Pressure	bar	45
Air Purge Pressure	bar	0.3 – 0.5
Lubrication Volume	cm <sup>3</sup>	0.04 – 0.06
Lubrication Frequency		Working Cycle (or every 6 minutes)
Repeatability	mm	±0.001
Mass	kg	11
Max Lifting Capacity	Kg	43

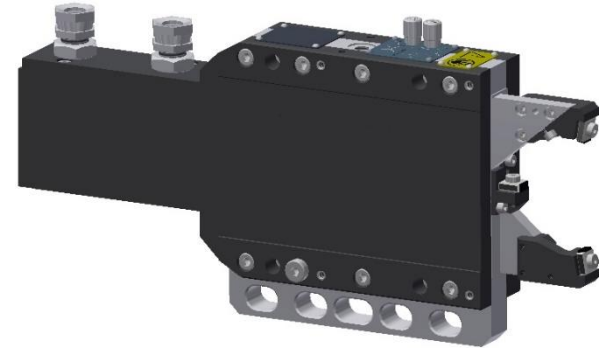

- Included Features**
- \* Arm Retraction for Part Loading
  - \* Fixed or Follow Down Operation
  - \* 2-Axis Centerline Adjustment
  - \* 90° = 0.001mm Adjustment
  - \* Visible Zero Adjustment Screws
  - \* Position Feedback Sensors

- Items Required To Use This Product:**
- \* Set of Nests
  - \* Set of Wear Pads
  - \* Mounting Base



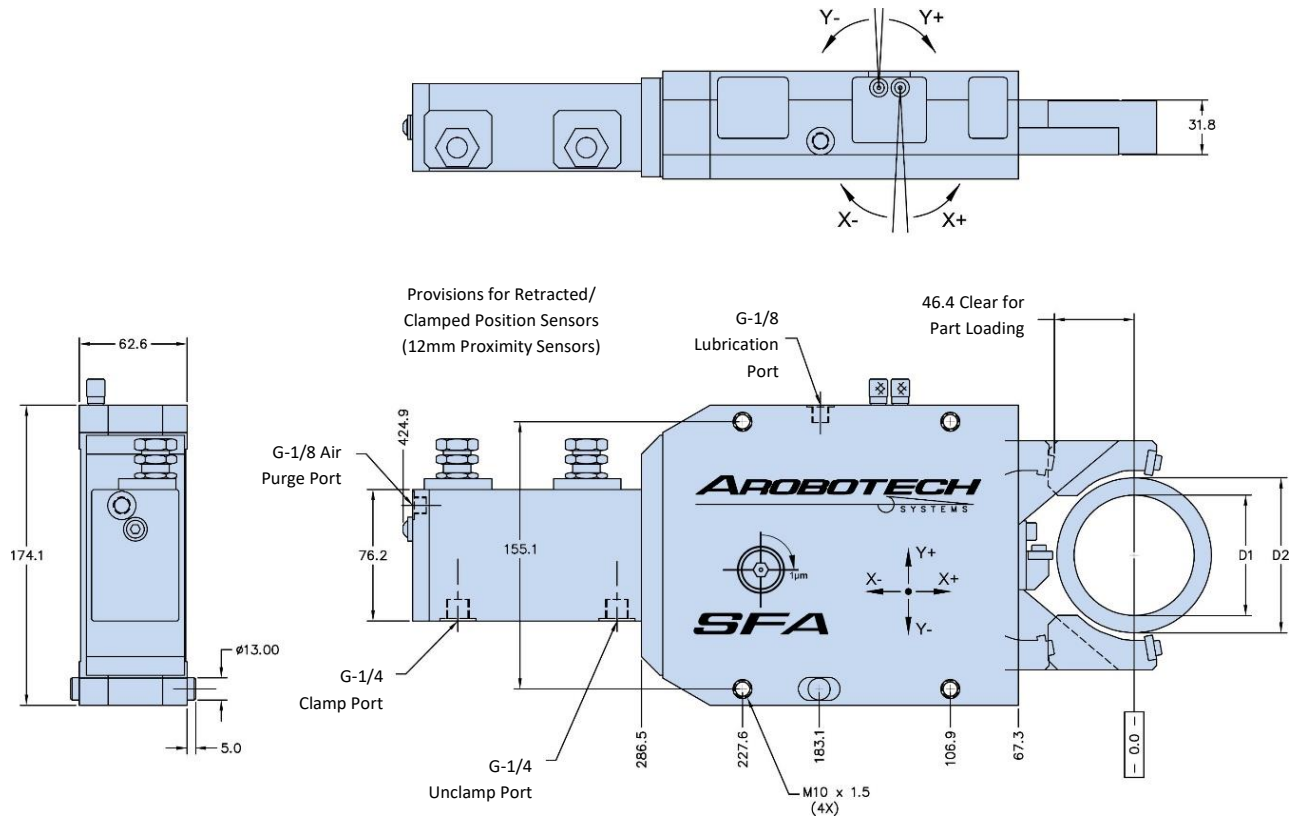

Nest Set			1	2	3	4
Minimum Clamp Diameter	D1	mm	10	30	50	70
Maximum Clamp Diameter	D2	mm	30	50	70	90

X-Axis Adjustment per Screw Rotation	mm	0.004
X-Axis Adjustment Total	mm	±0.20
Y-Axis Adjustment per Screw Rotation	mm	0.004
Y-Axis Adjustment Total	mm	±0.20
Piston Area	cm <sup>2</sup>	11.4
Cylinder Stroke	mm	76
Operating Pressure	bar	15 – 30
Maximum Pressure	bar	45
Air Purge Pressure	bar	0.3 – 0.5
Lubrication Volume	cm <sup>3</sup>	0.05 – 0.10
Lubrication Frequency		Working Cycle (or every 6 minutes)
Repeatability	mm	±0.001
Mass	kg	18
Max Lifting Capacity	Kg	78

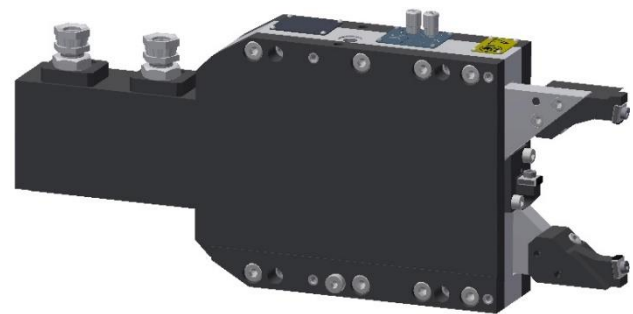

#### Included Features

- \* Arm Retraction for Part Loading
- \* Fixed or Follow Down Operation
- \* 2-Axis Centerline Adjustment
- \* 90° = 0.001mm Adjustment
- \* Visible Zero Adjustment Screws
- \* Position Feedback Sensors

#### Items Required To Use This Product:

- \* Set of Nests
- \* Set of Wear Pads
- \* Mounting Base

## Product Overview - Crankshaft Models

Available features:

- Arm Retraction for Part Loading
- Extended Reach for Counterweight Clearance
- Fixed or Follow Down Operation
- 2-Axis SFA 0.001mm / 90° Centerline Adjustment
- Visible Zero Adjustment Screws
- Upper Arm Gage Clearance
- Position Feedback Sensors
- Lower Mounting Rail
- Side Mount Cylinder

\*\*\* See Data Sheet for Specific Features of Each Model \*\*\*

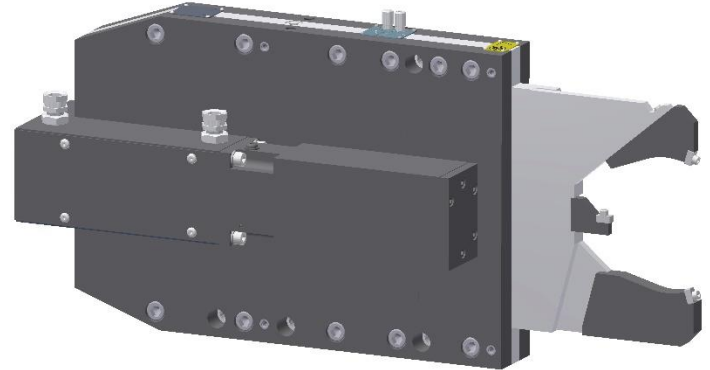

Model		GR-6000						GR-6100			
Replaces		GR-1150V-SDG						GR-1350V-SG			
Clamp Range	mm	15 – 95						43 - 95			
<b>Nest Set 1</b>		15 – 25						43 – 56			
<b>Nest Set 2</b>			25 – 45						56 - 69		
<b>Nest Set 3</b>				35 - 55						69 – 82	
<b>Nest Set 4</b>					45 – 65						83 – 95
<b>Nest Set 5</b>						55 – 75					
<b>Nest Set 6</b>							65 – 86				
<b>Nest Set 7</b>								75 - 95			

Model		GR-6200						GR-6300			
Replaces		GC29403A						GC30916A			
Clamp Range	mm	60 - 130						40 - 140			
<b>Nest Set 1</b>		60–70						40-62			
<b>Nest Set 2</b>			70-80						62-74		
<b>Nest Set 3</b>				80-90						74-96	
<b>Nest Set 4</b>					90-100						96-118
<b>Nest Set 5</b>						100-110					
<b>Nest Set 6</b>							110-120				
<b>Nest Set 7</b>											118-140

Contact sales@arobotech.com for free assistance

- |                       |                  |                    |                  |               |
|-----------------------|------------------|--------------------|------------------|---------------|
| * Model Selection     | * Process Review | * Special Models   | * 3D Models      | * Accessories |
| * Machine Integration | * Modifications  | * Special Features | * Mounting Bases | * Spare Parts |

Contact Us For Full Technical Details And Customer Service

sales@arobotech.com

www.arobotech.com

# Grinding AUTO REST® | GR-6000-000

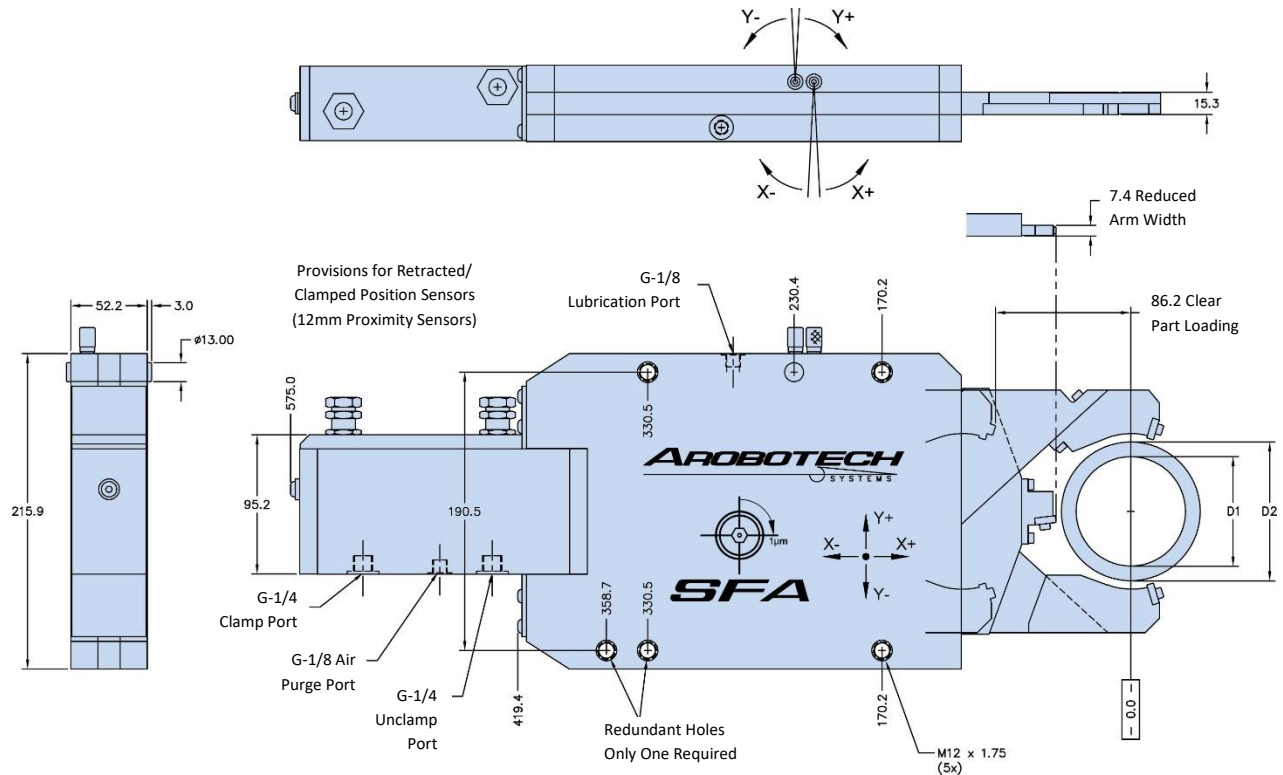

Nest Set			1	2	3	4	5	6	7
Minimum Clamp Diameter	D1	mm	15	25	35	45	55	65	75
Maximum Clamp Diameter	D2	mm	35	45	55	65	75	85	95

X-Axis Adjustment per Screw Rotation	mm	0.004
X-Axis Adjustment Total	mm	±0.20
Y-Axis Adjustment per Screw Rotation	mm	0.004
Y-Axis Adjustment Total	mm	±0.20
Piston Area	cm <sup>2</sup>	11.4
Cylinder Stroke	mm	125.2
Operating Pressure	bar	10 – 27
Maximum Pressure	bar	32
Air Purge Pressure	bar	0.3 – 0.5
Lubrication Volume	cm <sup>3</sup>	0.10 – 0.15
Lubrication Frequency		Working Cycle (or every 6 minutes)
Repeatability	mm	±0.001
Mass	kg	27
Max Lifting Capacity	Kg	83

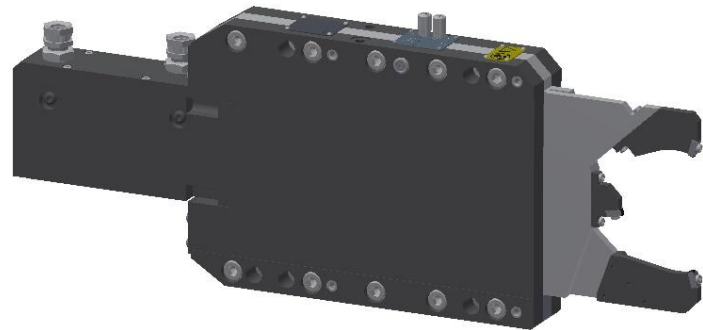

#### Included Features

- \* Arm Retraction for Part Loading
- \* Extended Reach for Clearance
- \* Fixed or Follow Down Operation
- \* Upper Arm Gage Clearance
- \* 2-Axis Centerline Adjustment
- \* 90° = 0.001mm Adjustment
- \* Position Feedback Sensor
- \* Visible Zero Adjustment Screw

#### Items Required to Use This Product:

- \* Set of Nests
- \* Set of Wear Pads
- \* Mounting Base

Contact Us For Full Technical Details And Customer Service

[sales@arobotech.com](mailto:sales@arobotech.com)

[www.arobotech.com](http://www.arobotech.com)

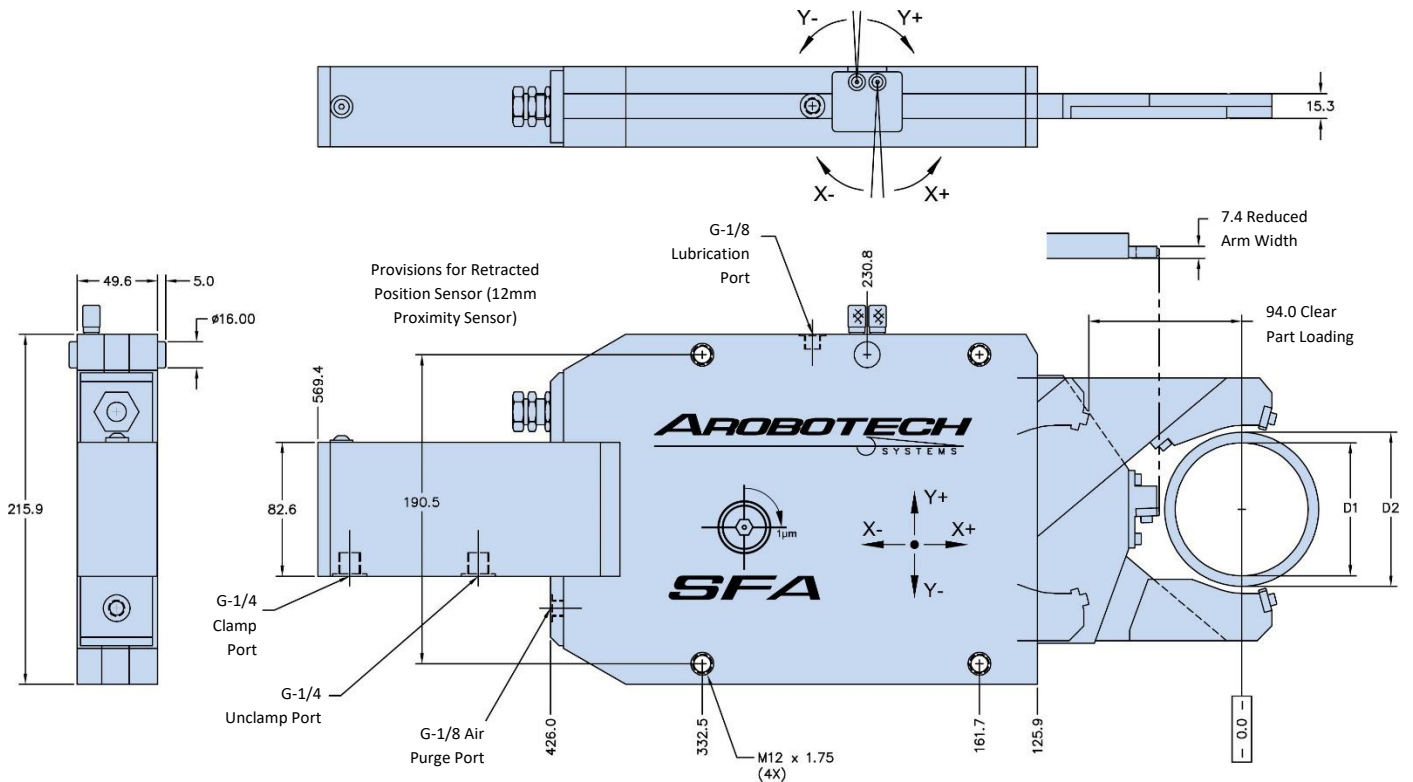

Nest Set			1	2	3	4
Minimum Clamp Diameter	D1	mm	43	56	69	82
Maximum Clamp Diameter	D2	mm	56	69	82	95

X-Axis Adjustment per Screw Rotation	mm	0.004
X-Axis Adjustment Total	mm	±0.20
Y-Axis Adjustment per Screw Rotation	mm	0.004
Y-Axis Adjustment Total	mm	±0.20
Piston Area	cm <sup>2</sup>	11.4
Cylinder Stroke	mm	127
Operating Pressure	bar	10 – 27
Maximum Pressure	bar	32
Air Purge Pressure	bar	0.3 – 0.5
Lubrication Volume	cm <sup>3</sup>	0.15 – 0.20
Lubrication Frequency		Working Cycle (or every 6 minutes)
Repeatability	mm	±0.001
Mass	kg	24
Max Lifting Capacity	Kg	70

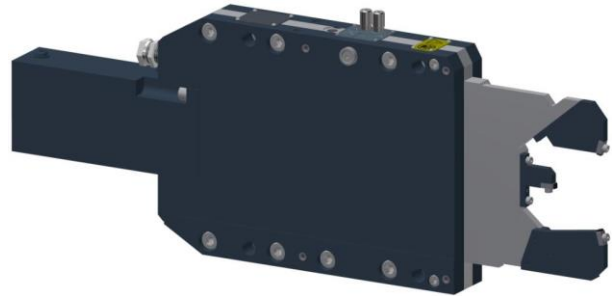

#### Included Features

- \* Arm Retraction for Part Loading
- \* Extended Reach For Clearance
- \* Fixed or Follow Down Operation
- \* Upper Arm Gage Clearance
- \* 2-Axis Centerline Adjustment
- \* 90°= 0.001mm Adjustment
- \* Position Feedback Sensor
- \* Visible Zero Adjustment Screw

#### Items Required To Use This Product:

- \* Set of Nests
- \* Set of Wear Pads
- \* Mounting Base

Contact Us For Full Technical Details And Customer Service

sales@arobotech.com

www.arobotech.com

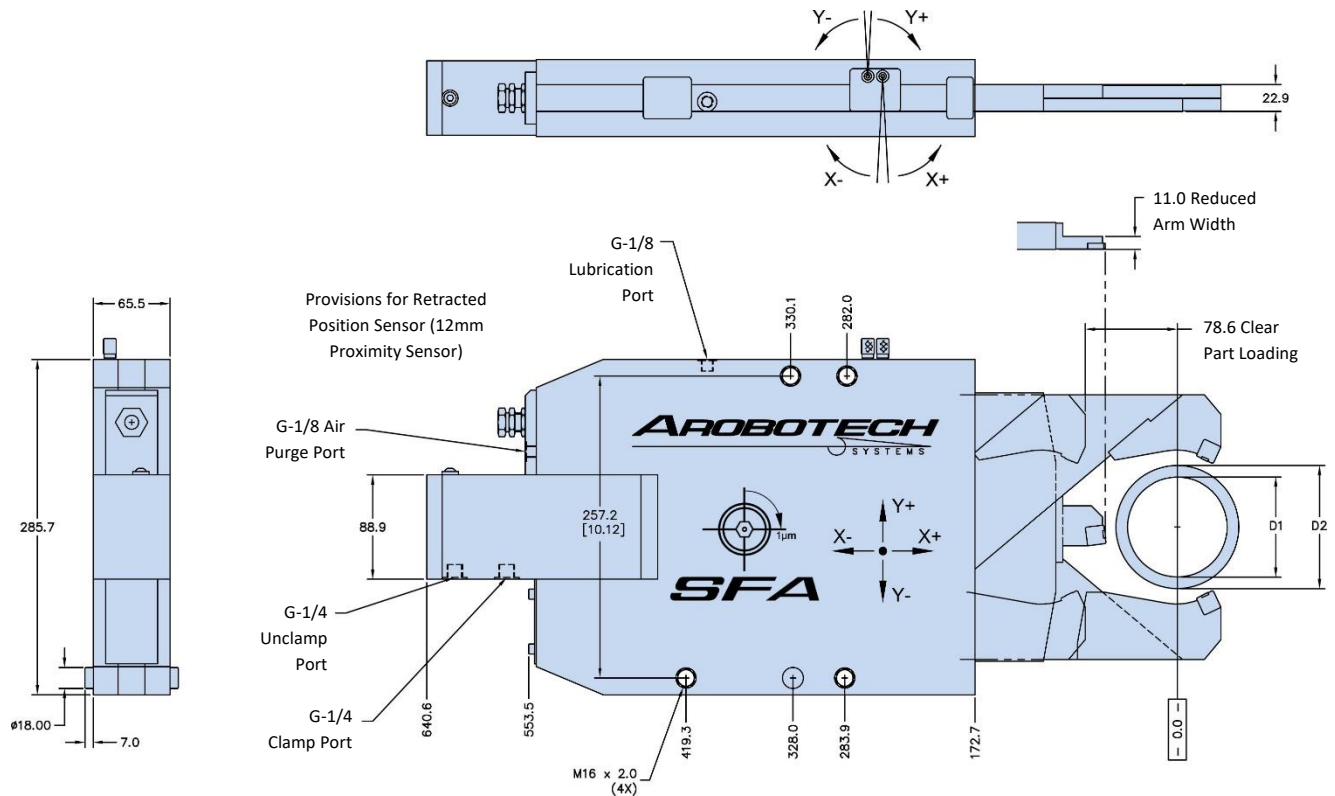

Nest Set			1	2	3	4	5	6	7
Minimum Clamp Diameter	D1	mm	60	70	80	90	100	110	120
Maximum Clamp Diameter	D2	mm	70	80	90	100	110	120	130

X-Axis Adjustment per Screw Rotation	mm	0.004
X-Axis Adjustment Total	mm	±0.20
Y-Axis Adjustment per Screw Rotation	mm	0.004
Y-Axis Adjustment Total	mm	±0.20
Piston Area	cm <sup>2</sup>	20.3
Cylinder Stroke	mm	135
Operating Pressure	bar	10 – 27
Maximum Pressure	bar	32
Air Purge Pressure	bar	0.3 – 0.5
Lubrication Volume	cm <sup>3</sup>	0.25 – 0.35
Lubrication Frequency		Working Cycle (or every 6 minutes)
Repeatability	mm	±0.001
Mass	kg	50.4
Max Lifting Capacity	Kg	125



#### Included Features

- \* Arm Retraction for Part Loading
- \* Extended Reach For Clearance
- \* Fixed or Follow Down Operation
- \* Upper Arm Gage Clearance
- \* 2-Axis Centerline Adjustment
- \* 90° = 0.001mm Adjustment
- \* Position Feedback Sensor
- \* Visible Zero Adjustment Screw

#### Items Required To Use This Product:

- \* Set of Nests
- \* Set of Wear Pads
- \* Mounting Base

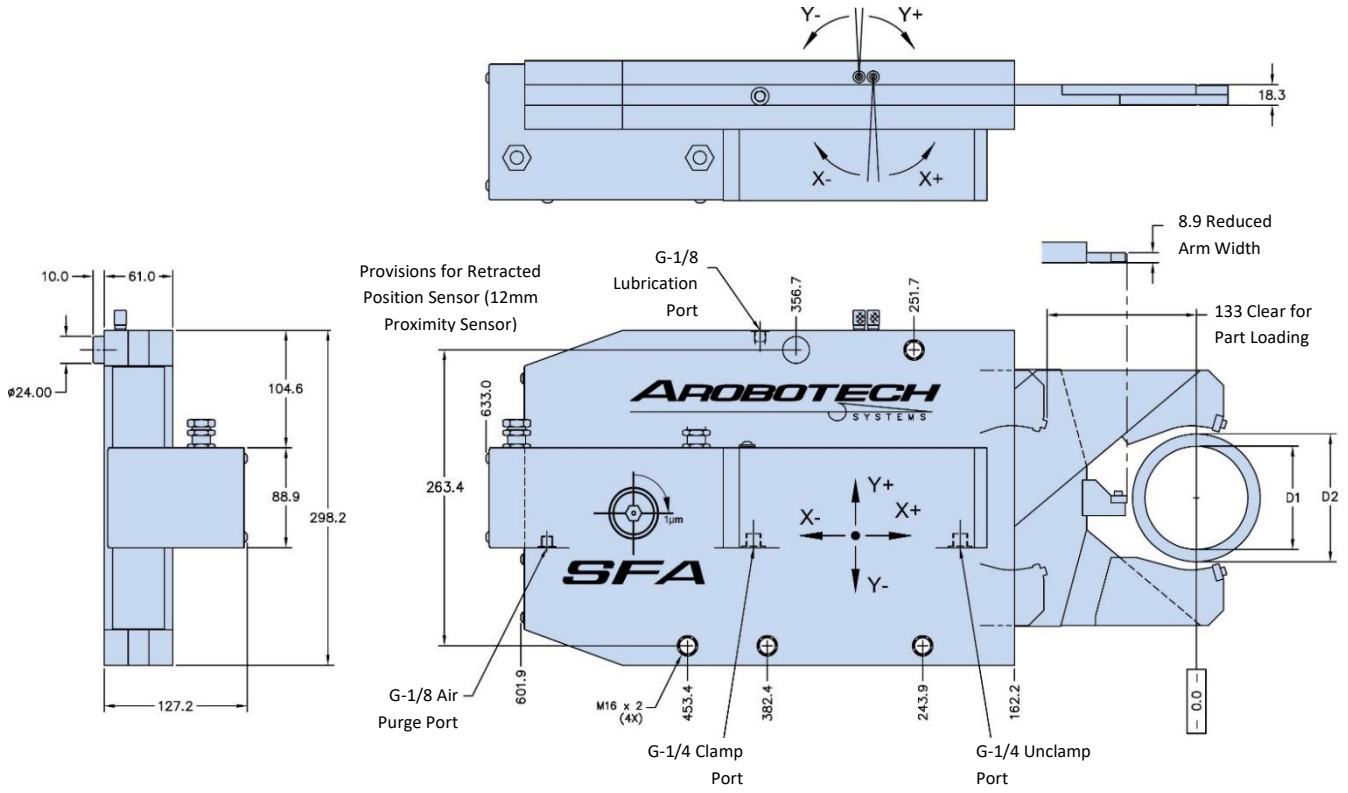

Nest Set			1	2	3	4	5
Minimum Clamp Diameter	D1	mm	30	52	74	96	118
Maximum Clamp Diameter	D2	mm	52	74	96	118	140

X-Axis Adjustment per Screw Rotation	mm	0.004
X-Axis Adjustment Total	mm	±0.20
Y-Axis Adjustment per Screw Rotation	mm	0.004
Y-Axis Adjustment Total	mm	±0.20
Piston Area	cm <sup>2</sup>	20.3
Cylinder Stroke	mm	178
Operating Pressure	bar	10 – 27
Maximum Pressure	bar	32
Air Purge Pressure	bar	0.3 – 0.5
Lubrication Volume	cm <sup>3</sup>	0.25 – 0.35
Lubrication Frequency		Working Cycle (or every 6 minutes)
Repeatability	mm	±0.001
Mass	kg	64
Max Lifting Capacity	Kg	127

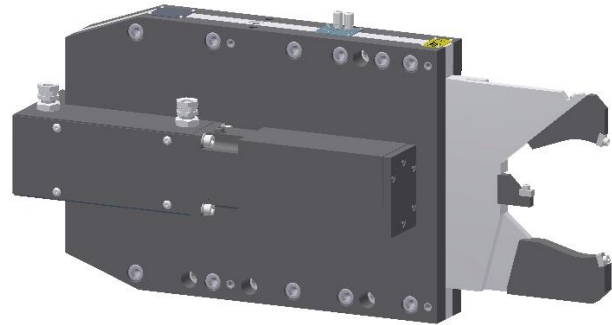

#### Included Features

- \* Arm Retraction for Part Loading
- \* Extended Reach for Clearance
- \* Fixed or Follow Down Operation
- \* Upper Arm Gage Clearance
- \* 2-Axis Centerline Adjustment
- \* 90° = 0.001mm Adjustment
- \* Position Feedback Sensor
- \* Visible Zero Adjustment Screw

#### Items Required To Use This Product:

- \* Set of Nests
- \* Set of Wear Pads
- \* Mounting Base



Warning! Grinding AUTO REST®s are hydraulically operated. Care must be taken at all times to avoid injury or damage to equipment



Under no circumstances will this document take precedent over the machine builder operating and safety guidelines

## Hydraulic Diagram

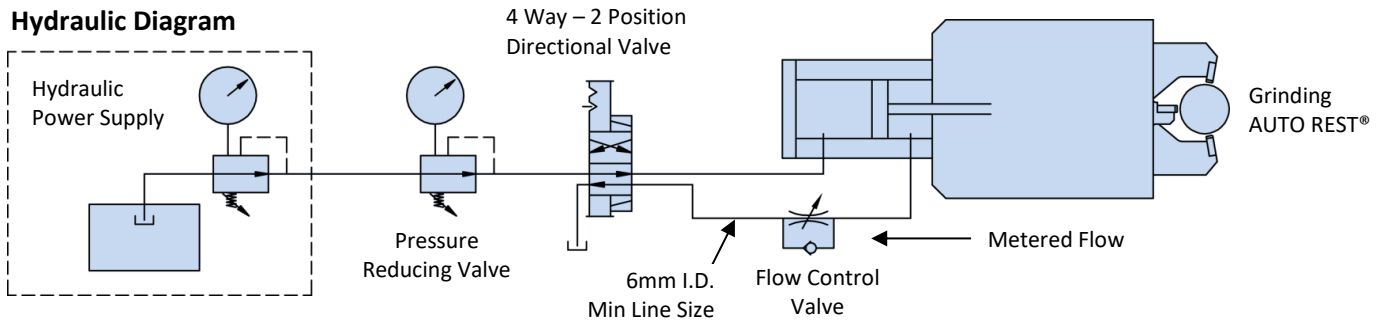

## Air Purge

Grinding AUTO REST® uses Air Purge port to pressurize inside the body for maximum service life

0.3 to 0.5 bar recommended pressure

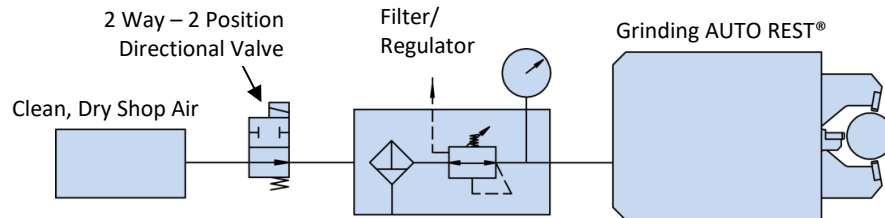

## Hydraulic

Grinding AUTO REST® uses a single hydraulic cylinder to extend and clamp on the part. The same cylinder is then used to open and retract the arms. The basic hydraulic recommendation:

- Recommended Hydraulic Power Supply = 3GPM (11 LPM) @ 500 psi (34 bar) minimum. See operator's manual for specific model recommended operating pressure. Hydraulic pump must maintain pressure to the rest when clamped and unclamped
- 4 way - 2 position solenoid valve with a pressure reducing valve for each Grinding AUTO REST®
- Flow control valve for each Grinding AUTO REST® - 1 second recommended clamping time

## Electrical

### Machine control interface

Interface to machine control must be supplied by the machine builder. Arobotech Systems does not supply a machine control interface.

### Position sensors

Each Grinding AUTO REST® has integrated sensor mounting for barrel type proximity sensor. Sensors are used to alert the machine control of the steady rest position. Please note that it is the responsibility of the customer to supply proximity sensors. See operator's manual for specific model sensor size.

### Machine door

Prepare the machine so that the Grinding AUTO REST® can be operated in manual mode with the door open. Always follow valid safety regulations.

## Lubrication

Machine must be capable of delivering lubrication oil to each Grinding AUTO REST® every 6 minutes or each working cycle (whichever is more frequent). See operator's manual for specific model volume recommendations.

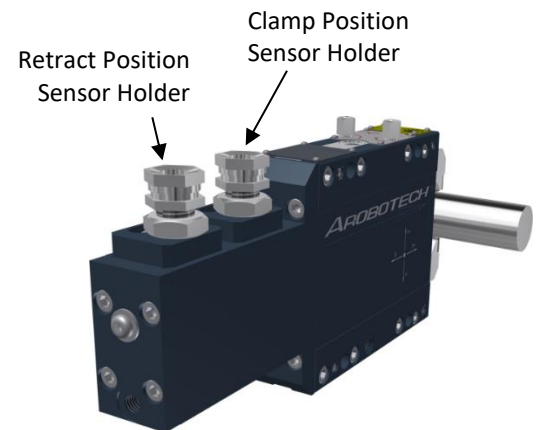

# Grinding AUTO REST® | Mounting

Over-Sized Holes Recommended For Mounting Screws

Screw Size	Hole Size In Bracket
M6	8.0
M8	10.5
M10	13.5
M12	16.0
M16	20.5
M20	25.0

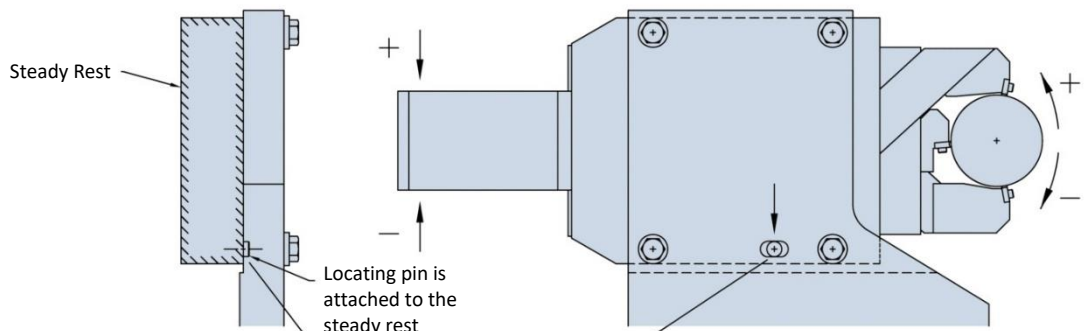
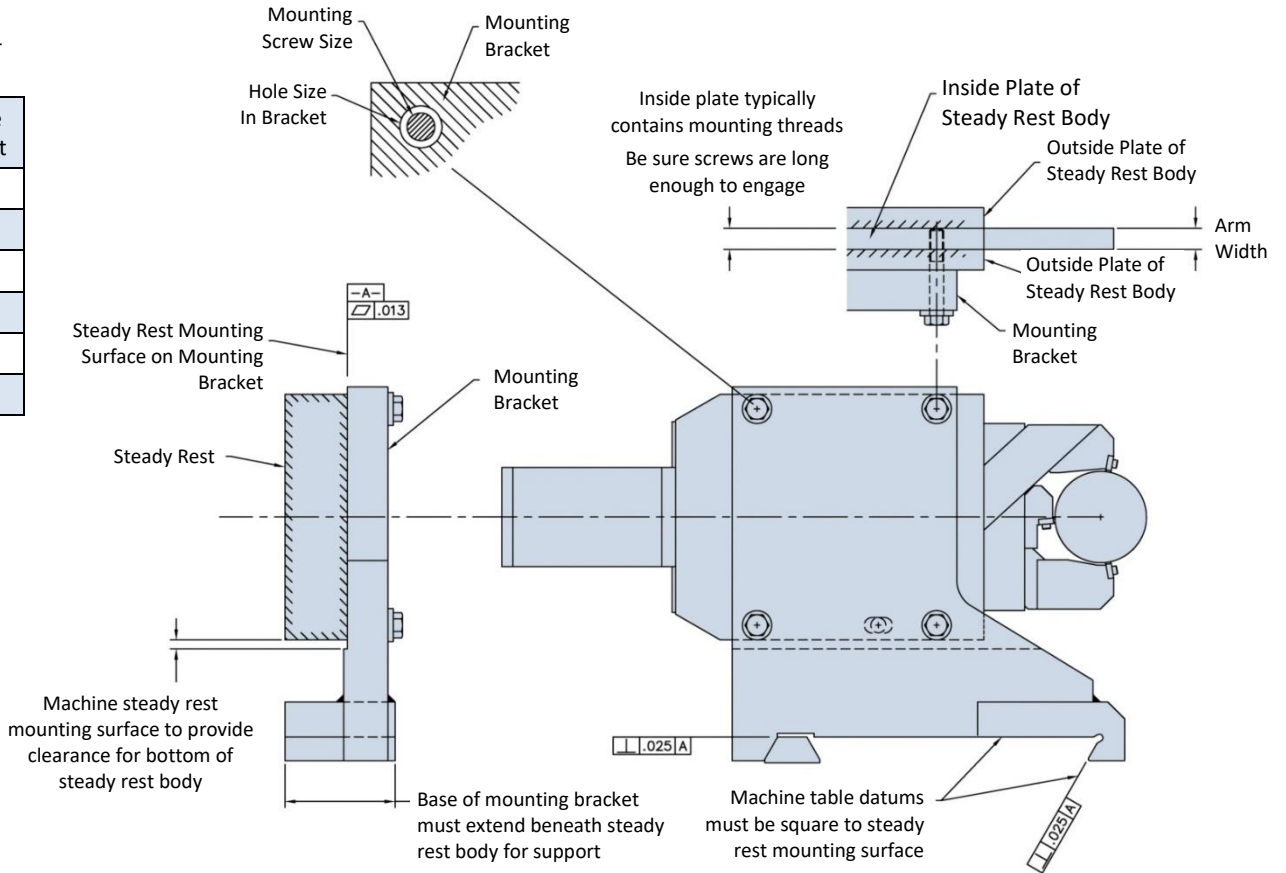

The locating pin and slot are critical to steady rest alignment and must be included in bracket design

Locating Pin Size	Slot Size	Slot Length	Slot Depth
13.00	13.50	13.0	10.0
16.00	16.50	16.0	12.0
18.00	18.50	18.0	14.0
24.00	24.50	24.0	16.0

Contact Us For Full Technical Details And Customer Service

sales@arobotech.com

www.arobotech.com



Arobotech offers a full complement of accessories for use with our Grinding AUTO REST® products

- Mounting Bracket
- Hydraulic Power Supply
- Lubricator
- Valve Package
- Pre-Position Vee Cradles
- Master Set Up Bar
- Alignment Gage
- Specialty Tooling

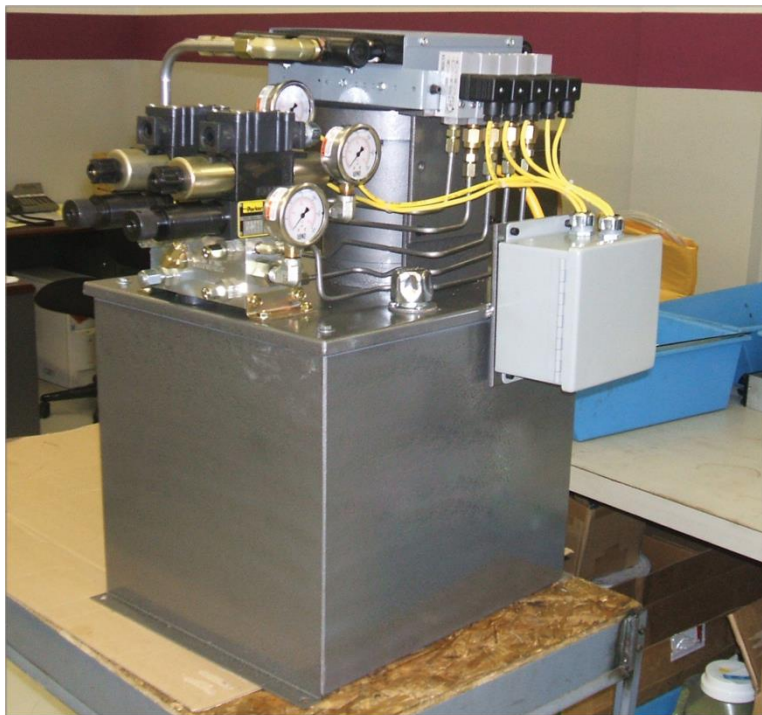

## Our commitment

Arobotech Systems is a full service company. Our relationship with the customer does not end at the point of sale and delivery. When you purchase an Arobotech product you gain not only a superior workholding device, but also many years of experience with workholding solutions.

Arobotech offers full support to all of our products for their entire service life.



## Available Services

### Installation

Arobotech has experienced personnel to assist with Grinding AUTO REST® and accessories

### Training

Our staff offers experienced on-site training for your engineering and production staff

### Troubleshooting

We bring many years of experience to troubleshooting your Grinding AUTO REST® and grinding process. Contact [service@arobotech.com](mailto:service@arobotech.com) for support. On site troubleshooting is available.

### Repair and Reconditioning

[service@arobotech.com](mailto:service@arobotech.com)

## Repair and Reconditioning Service

Arobotech offers complete repair and reconditioning service. Damaged or worn units can be returned for a free-of-charge performance / condition evaluation

Old Unit

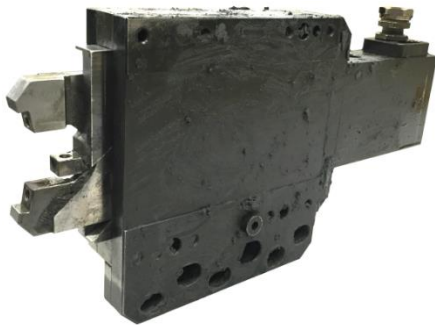

Repaired / Reconditioned Unit

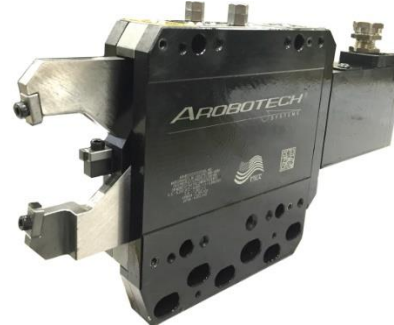

## Return for Evaluation

All Returns Require an RMA Number - Contact us at to request an RMA number  
[www.arobotech.com/service/](http://www.arobotech.com/service/)  
 +001 248-588-9080  
[service@arobotech.com](mailto:service@arobotech.com)

Authorized products may be returned to Arobotech for a performance / condition evaluation at no charge with the following conditions:

- Include RMA number on outside of the shipping container and all shipping documents
- Label "Return for Evaluation"
- Include a description of the symptom or failure that prompted the return (as described on the RMA)
- Include contact information (as listed on the RMA)
- Packaging should be sufficient to prevent damage during transit
- Customer is responsible for all shipping charges

Ship subject unit(s) to:  
**Arobotech Systems**  
 1524 E. Avis Drive  
 Madison Heights, MI 48071  
 USA

Shipments from outside the United states also must have noted on all paperwork: **"These goods were manufactured in the United States and are being returned for repair"**

Shipping terms must be DDP

Contact us with any questions:  
 +001 248-588-9080  
[sales@arobotech.com](mailto:sales@arobotech.com)

Notify us at [sales@arobotech.com](mailto:sales@arobotech.com) when shipment is made so we can track and prepare our evaluation team

## Evaluation Report

Our team will perform a full evaluation and issue a report (including cost to repair / recondition). Please allow 2 weeks for the evaluation report after receipt at our facility.

Once the evaluation report is complete, we require one of the following actions within the 90 day evaluation period:

- Purchase order to begin repairs
- Return unit as is with no repair
- Scrap at our facility (written direction required)

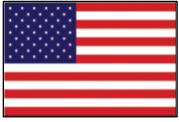

Arobotech Systems, Inc.  
World Headquarters  
1524 E. Avis Drive  
Madison Heights, MI 48071  
USA  
+001 (248) 588-9080  
+001 (248) 588-9370 (fax)  
Sales@arobotech.com  
Service@arobotech.com



GSN Schleiftechnik GmbH  
Im Moosfeld 5  
73495 Stödtlen  
Germany  
+49 (0)7964 – 33111 790  
info@arobotech.de

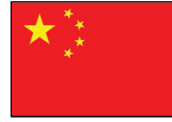

AMT Shanghai Technology  
and Service Center (AMT STC)  
No.8 Building, No.81 MeiYue Road  
China (Shanghai) Pilot F.T.Z.  
Shanghai, 200131, P.R. China  
+86 21 5868 2809 - 109  
+86 21 5868 2803 (fax)  
Info@arobotech.cn



P R Sales Corporation Pvt. Ltd.  
Flat 3. Kedar Apartments  
Plot 48, Mayur Colony, Kothrud  
Pune, Maharashtra 411038  
India  
Tel. +91-20-25437591  
Fax +91-20-25445255  
info@prsales.in



Seong Eun Tech.  
294-1, Sangbuk-ro,  
Sangbuk-myeon, Ulju-gun,  
Ulsan 689-821 Korea  
+82 052 256 5758  
+82 052 256 5760 (fax)  
Info@arobotech.co.kr

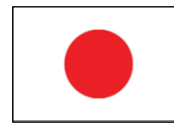

Mitsubishi Corporation Technos  
Dai Nagoya Building, 3-28-12,  
Meieki Nakamura  
Nagoya City, Aichi Prefecture  
450-6418 Japan  
+81-52-565-2641  
+81-52-565-1989 (fax)  
e100\_arobotech@mmts.co.jp

**WE ARE YOUR BEST TECHNOLOGY**

**www.arobotech.com**